

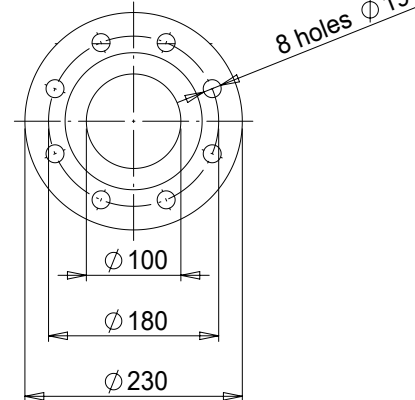

1:8 EN 1092-2 DN 100 PN 16  
 \*EN 1092-2 dimension  $\phi 220$



|  |                                      |   |   |                                      |                 |
|--|--------------------------------------|---|---|--------------------------------------|-----------------|
| Note:<br>Notes:  |                                      |   | Tolleranze non indicate:<br>Tolerances not indicated: |                                      |                 |
| Smussi non quotati:<br>Unlisted chamfers:  | Raggi non quotati:<br>Unlisted rays: | Sforni non quotati:<br>Unlisted draft angles: | Finitura:<br>Surface quality:                         |                                      |                 |
| Descrizione / Description:<br><br><b>POMPA MXV 100-6502-2R/A-60 CON MOTORE</b>   |                                      |   | Quota di controllo:<br>Control dimension:             |                                      |                 |
|  |                                      |   | Materiale:<br>Material:                               |                                      |                 |
|  |                                      |   | Trattamenti:<br>Treatments:                           |                                      |                 |
|    | Formato:<br>Size: <b>A4</b>          | Modello-Stampo:<br>Model-Mold:                | Peso grezzo kg:<br>Raw weight kg:                     | Peso finito kg:<br>Finish weight kg: |                 |
|  | Dimensioni in mm<br>Dimensions in mm | Dipartimento:<br>Department: <b>Z01</b>       | N° Disegno / Drw N°:                                  | Vers:                                | Foglio / Sheet: |
| Scala / Scale:<br>1:1  | Data / Date:<br>26.04.2023           | Disegnato / Drawn:<br>DS00367                 | Approvato / Checked:<br>DS00155                       | <b>4.93.632.23</b>                   | <b>01</b>       |
| <p>A norma di legge è rigorosamente vietato riprodurre o comunicare a terzi il contenuto, anche parziale, del presente disegno / According to law is strictly forbidden any partial or total reproduction or communication of this drawing</p> |                                      |   |   |                                      |                 |